

OPERATING INSTRUCTION

LEHMAN EQUIPMENT/STUDIO STAR MIXER/RECLAIMER

MODELS: BR6, MITY MITE

IMPORTANT:

DO NOT ATTEMPT TO USE YOUR MIXER/RECLAIMER WITHOUT READING THE OPERATING INSTRUCTIONS AND FULLY UNDERSTANDING ITS OPERATION. CHECK THE MACHINE FOR DAMAGE CAUSED IN SHIPMENT BEFORE ATTEMPTING TO USE IT.

WARNING:

THE MOTOR ON THESE MACHINES IS EQUIPPED WITH A GROUNDED ELECTRICAL CORD. ALWAYS BE SURE THE MOTOR IS FULLY GROUNDED. IF THE RECEPTACLE (OUTLET) YOU ARE USING IS NOT GROUNDED, IT IS RECOMMENDED THAT YOU HAVE A GROUND LINE INSTALLED. AN **UNGROUND CORD CAN CAUSE SEVERE ELECTRICAL SHOCK!!!**

PREPARING YOUR MACHINE FOR USE:

These models may require some very simple assembly. Once assembly is complete, you are ready to test the mixer. Turn the mixer on and run it for a short period of time to make sure all of the parts are turning freely. Also listen for rattling or vibrating sounds that could indicate that something is not tightened properly.

USING YOUR LEHMAN MIXER/RECLAIMER:

Your mixer can be used either to mix slip from dry bagged materials or to reclaim trimmings. To mix slip from dry materials, start by adding water as recommended by the source of your materials. Add the clay materials slowly to maintain the vortex (whirlpool mixing action) in the tank. If you lose the vortex, let the mixer catch up before adding any more material. Once the slip has been tested to the proper specific gravity (weight) and viscosity (thickness), it is ready to use.

Reclaiming is much like mixing slip from dry materials. Start by putting water in the tank. For example, put 2 or 2 1/2 gallons in a mity mite. Add some trimmings to the water and allow them to absorb as much water as they will. (For best results, soak all trimmings in a bucket of water before putting them in the tank. You will find that it is much easier if they are totally soaked and mushy before you put them in the mixer. You should start with less water in the tank if the trimmings have already been soaked.) When they are sufficiently soaked, turn the motor on and let it mix. Do not try to reclaim too much at one time. Fill the tank to about 1/3 of its capacity and mix that amount. When that slip is fluid and of a smooth consistency, turn the mixer off and add more wet trimmings. Do not ADD TRIMMINGS WITH THE MIXER RUNNING! Use only enough water to maintain a vortex. When you have finished mixing, test the specific gravity and viscosity and adjust as necessary. Properly reclaimed slip can be added at a rate of one-gallon reclaim to three or four gallons of new slip. Reclaimed slip should be screened to remove any lumps and impurities.

The information above is very general. For more specific instructions on mixing and reclaiming slip, refer to our sheet entitled "successful mixing and reclaiming."

The life of your mixer/reclaimer will be determined by the care that you give the machine. It is in your best interest to **KEEP IT CLEAN!** The fiberglass lids and polyethylene tank of your machine may be scraped with a plastic or wooden utensil. A rubber squeegee works best to keep the liquid pushed down in the tank. Do not use a metal scraper, as it will permanently scratch the fiberglass and plastic.

The spigot of your mixer/reclaimer can become clogged with dried slip. To help prevent this, unscrew the spigot 1/2 turn so the outlet hole is facing up and fill it with water.

**If you need technical assistance or need to order parts, you may contact our
SERVICE DEPARTMENT at:
LEHMAN MFG.
304 N Fairground Rd.
Kentland, IN 47951
219-474-6011 • FAX LINE 219-474-6014**

Our hours are 8am to 5pm cst Monday thru Thursday.
Please have your model and serial number ready when you call.

LEHMAN STUDIO STAR MIXER/RECLAIMER SCHEMATIC EQUIPMENT

MODELS: BR6, MITY MITE

BR6

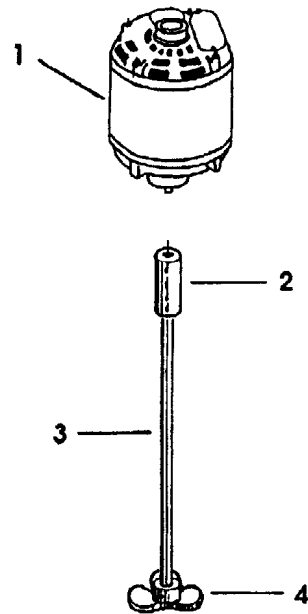
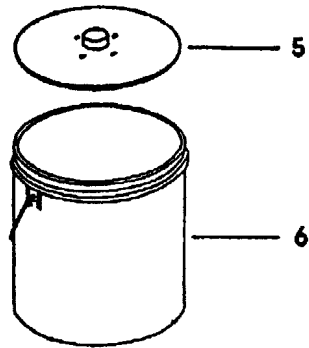

MITY MITE

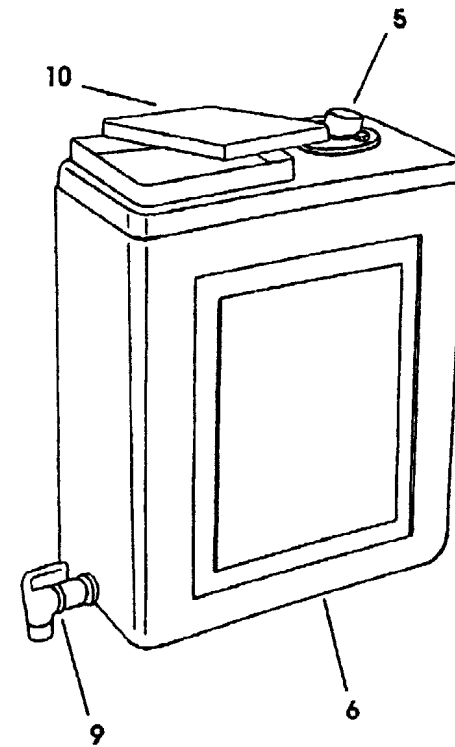

BR4 / MITY MITE Parts List

NO.	PART DESCRIPTION	BR6	MITY MITE
1	Motor	SP2050	SP2050
2	Rigid Coupling	25-5	25-5
3	Stainless Steel Shaft	B6500	MM500
4	Aluminum Propeller	300-4	300-4
5	Motor Mount	B6401	MM400
6	Tank	CC060	MM1001
9	Spigot Type Faucet	N/A	DF103

PARTS NOT SHOWN

Power Cord	1VEP4	1VEP4
------------	-------	-------

NOTES: